

# 6ft Deep Burial HOLDING Tanks

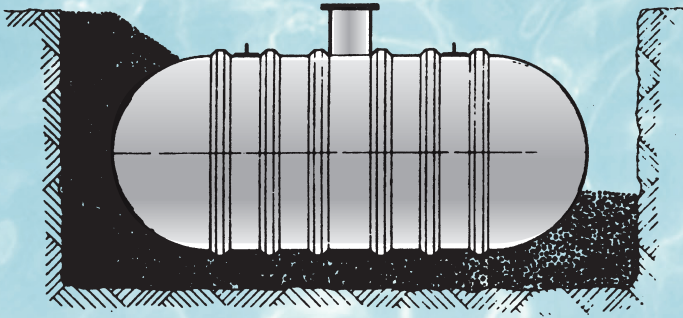

## 6 FOOT DIAMETER BURIAL TANKS

All Equinox 6 foot (1829 mm) diameter tanks are one piece construction. Each tank comes complete with a 24" (610 mm) diameter bonded access sleeve, a 4" (102 mm) ABS inlet fitting, an 8" (203 mm) pump-out access cover, and steel lift lugs. Compartment dividers are available at an additional cost.

### COMMERCIAL TANKS

### 6-Foot Diameter Deep Burial HOLDING Tanks

TANK SPECIFICATIONS				
MODEL	TANK LENGTH	APPROXIMATE SHIPPING SIZE	NOMINAL CAPACITY OF TANK	RETENTION CAPACITY OF WORKING CHAMBER
G-2000-H7-6	159 (4040)	78 x 159 (1980 x 4040)	2000 (9090)	2000 (9090)
G-2500-H7-6	192 (4953)	78 x 192 (1980 x 4953)	2500 (11365)	2500 (11365)
G-3000-H7-6	231 (5867)	78 x 231 (1980 x 5867)	3000 (13640)	3000 (13640)
G-3500-H7-6	267 (6782)	78 x 267 (1980 x 6782)	3500 (15910)	3500 (15910)

MANHOLE SLEEVES	
LENGTH	SLEEVE REQUIRED
30 (762)	1 x E-MES-30
60 (1524)	1 x E-MES-60
84 (2134)	1 x E-MES-84

NOTE: MAX. 7 ft (2138 mm) Burial

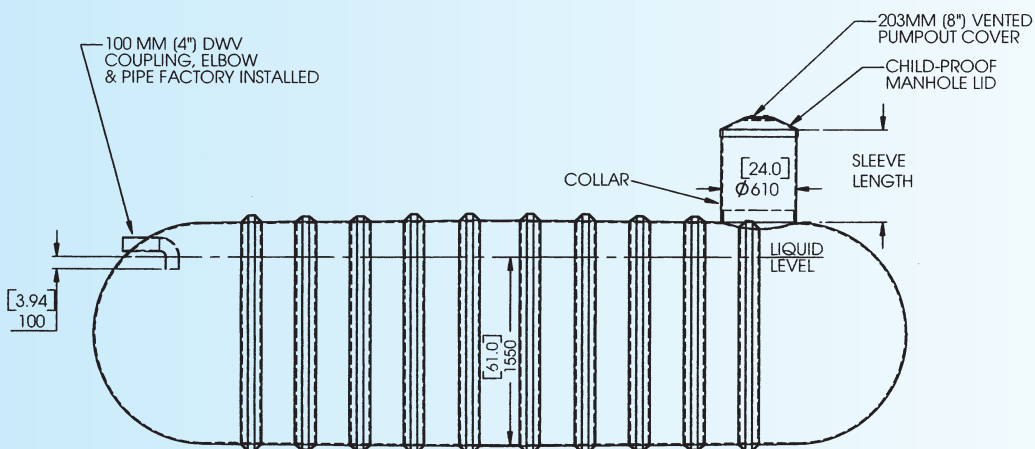
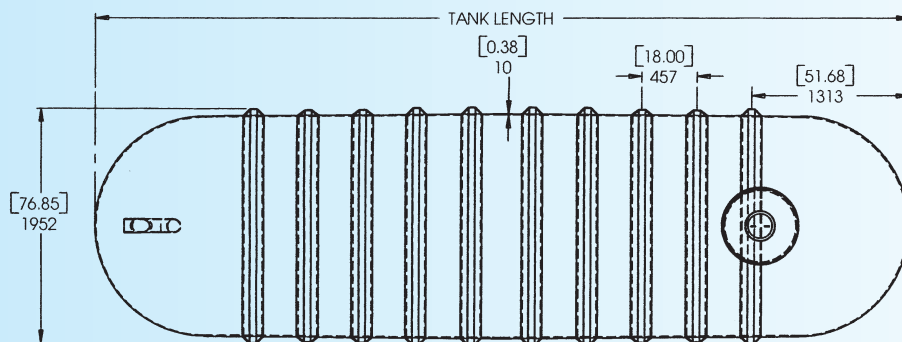

MODEL G-3500 SHOWN